









VK
systems

KATALOG 2019-2020

CONTENT

PRODUCT

UFA Line	3
Order overview UFA Line	4
Precision chuck with 6-jaws made of aluminium and brass	6
 Chuck without magnetic field with basic- and top jaws	6
 Clamping jaws 6 UFA complete (inside and outside clamping)	7
 Clamping jaws 6 UFA bloc	8
Order list UFA ring chucks line	9
Ring chuck made of aluminium and brass	11
 Form fit clamping without magnetic field	11
 Clamping jaws 6 UFA inside (inside clamping)	12
 Clamping jaws 6 UFA outside (outside clamping)	13
 Clamping jaws 6 UFA bloc	14

Contact



VK SYSTEMS PLC
Kastellstrasse 11
CH-8623 Wetzikon
Switzerland

PHONE
+41 44 970 20 00
E-MAIL
info@vk-systems.ch

UFA Line

All the chuck of the line UFA are made by highly firm aluminium. Due to the very hard ALTEF®-Coating the chuck are extremely resistant to abrasion, corrosion and scratching.

UFA lines are smooth-running and continuously adjustable.

UFA is available in a standard version with brass jaws. It is antimagnetic, extremely light and flat.

Concentricity	Repetitive accuracy	Lateral runout
0,03mm	0,01mm	0,01mm

Application:

Measuring technology



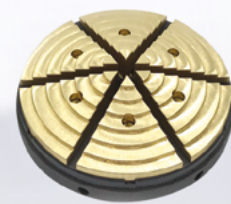



Automation

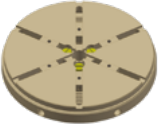

Fast clamping





	Article	Designation	Package Contents
CHUCK WITH 6- OR 8-JAWS MADE OF ALUMINIUM / BRASS			
	UFA.070.000	Chuck 6 UFA 70 basic	Chuck with 1-set basic jaws without top jaws , clamping key, TORX® screwdriver, cylinder head screws (brass)
	UFA.100.000	Chuck 6 UFA 100 basic	
	UFA.150.000	Chuck 8 UFA 150 basic	
	UFA.070.001	Chuck 6 UFA 70 complete	Chuck with 1-set basic jaws and reversible top jaws for inside and outside clamping , clamping key, TORX® screwdriver, head screws (brass)
	UFA.100.001	Chuck 6 UFA 100 complete	
	UFA.150.001	Chuck 8 UFA 150 complete	
	UFA.070.002	Chuck 6 UFA 70 bloc	Chuck with 1-set basic- and bloc jaws , clamping key, TORX® screwdriver, cylinder head screws (brass)
	UFA.100.002	Chuck 6 UFA 100 bloc	
	UFA.150.002	Chuck 8 UFA 150 bloc	
	UFA.070.006	Chuck 6 UFA 70 inside	Chuck with 1-set basic- and top jaws for inside clamping (brass)
	UFA.100.006	Chuck 6 UFA 100 inside	
	UFA.150.006	Chuck 8 UFA 150 inside	
	UFA.070.007	Chuck 6 UFA 70 outside	Chuck with 1-set basic- and top jaws for outside clamping (brass)
	UFA.100.007	Chuck 6 UFA 100 outside	
	UFA.150.007	Chuck 8 UFA 150 outside	
	UFA.070.008	Chuck 6 UFA 70 bloc	Chuck with 1-set basic- and bloc jaws (brass)
	UFA.100.008	Chuck 6 UFA 100 bloc	
	UFA.150.008	Chuck 8 UFA 150 bloc	
	UFA.070.009	Chuck 6 UFA 70 combi	Chuck with 1-set basic- and 2-set top jaws for inside and outside clamping (brass)
	UFA.100.009	Chuck 6 UFA 100 combi	
	UFA.150.009	Chuck 8 UFA 150 combi	



	Article	Designation	Information
CLAMPING JAWS FOR UFA LINE			
	UFA.070.014	Clamping Jaws 6 UFA 70 complete	Reversible top jaws for inside- and outside clamping (brass / ground)
	UFA.100.014	Clamping Jaws 6 UFA 100 complete	
	UFA.150.014	Clamping Jaws 8 UFA 150 complete	
	UFA.070.019	Clamping Jaws 6 UFA 70 bloc	Bloc jaws made of brass
	UFA.100.019	Clamping Jaws 6 UFA 100 bloc	
	UFA.150.019	Clamping Jaws 8 UFA 150 bloc	

CHUCK WITHOUT MAGNETIC FIELD WITH BASIC- AND TOP JAWS

Technical data and order overview Type UFA (6 or 8-jaw chuck)

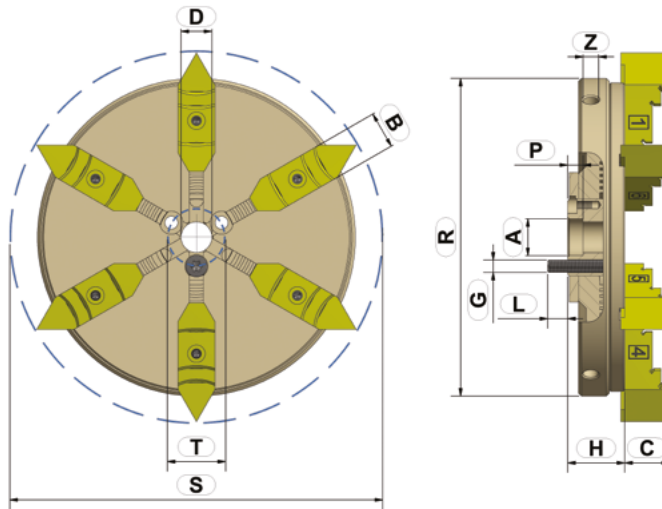

Sizes		70	100	150
A 0/+0,01	Interface [mm]	11	12	20
B	Jaw width [mm]	10	12	18
C	Jaw height (Standard) [mm]	10,5	14,5	18,5
D	∅ center hole [mm]	8	10	16
G	Fixing screws	3 x M3	3 x M4	4 x M5
H	Height without Jaws [mm]	16	18,5	21,5
L	Thread length [mm]	4,5	6,5	5
P	Fit length [mm]	5	5	5
R	Outside-∅ [mm]	73	103	153
S	Max. circuit diameter [mm]	87,5	119,5	183,5
T	Circle for mounting [mm]	17	18,8	28
Z	Clamping bore [mm]	3	5	5
	Concentricity [mm]	0,03	0,03	0,03
	Rotation speed n max. [1/min.]	2500	2000	1500
	Travel path [mm / ∅]	23,5	36,5	47
	Weight [kg]	0,2	0,4	1,4
	Order number (without jaws)	UFA.070.000	UFA.100.000	UFA.150.000

JAW SET 6 UFA COMPLETE (INSIDE AND OUTSIDE CLAMPING)

Technical data and order overview

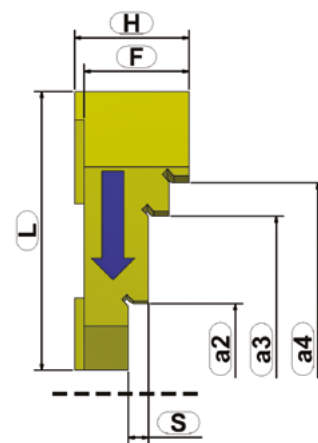
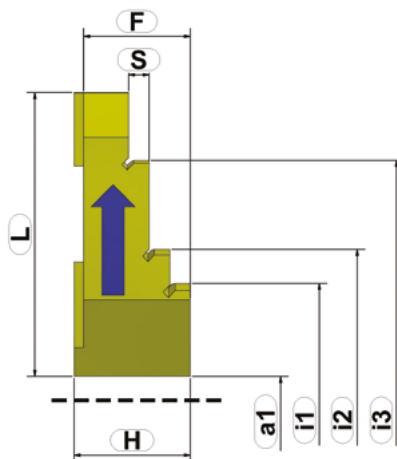
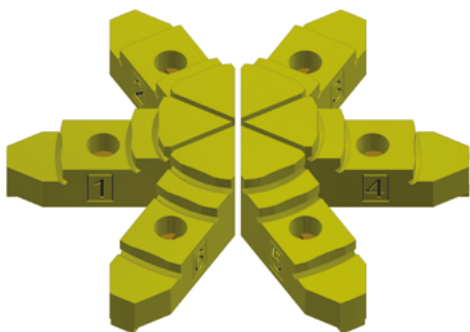

Sizes		70	100	150
a1	Clamping range outside	1 - 24	1 - 37	1 - 48
a2		28 - 50	34 - 69	51 - 98
a3		44 - 66	57 - 92	78 - 125
a4		56 - 78	68 - 103	104 - 151
i1	Clamping range inside	14 - 37	19 - 55	32 - 79
i2		26 - 50	36 - 72	70 - 117
i3		42 - 65	60 - 96	95 - 142
F	Height from Chuck body	10,5	14,5	18,5
H	Maximum height [mm]	11,5	15,5	19,5
L	Total length [mm]	26	38,5	60
S	Step height	2,3	2,8	4
	Jaw width [mm]	10	12	18
	Order number (without chuck)	UFA.070.013	UFA.100.013	UFA.150.013

JAW-SET 6 UFA BLOC (BLOCKBACK)





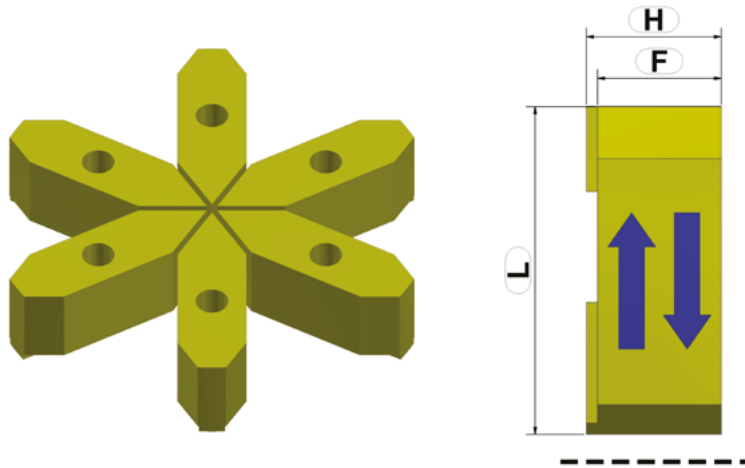



Technical data and order overview Type UFA (6 or 8-jaw chuck)

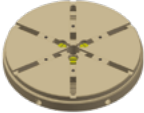



Sizes		70	100	150
F	Height from Chuck body	10,5	14,5	18,5
H	Maximum height [mm]	11,5	15,5	19,5
L	Total length [mm]	26	38,5	60
	Jaw width [mm]	10	12	18
	Order number (without chuck)	UFA.070.013	UFA.100.013	UFA.150.013



	Article	Designation	Package Contents
CHUCK WITH 6- OR 8-JAWS MADE OF ALUMINIUM / BRASS			
	UFA.070.000	Chuck 6 UFA 70 basic	Chuck with 1-set basic jaws without top jaws , clamping key, TORX® screwdriver, cylinder head screws (brass)
	UFA.100.000	Chuck 6 UFA 100 basic	
	UFA.150.000	Chuck 8 UFA 150 basic	
	UFA.070.006	Chuck 6 UFA 70 inside	Chuck with 1-set basic jaws and top jaws for inside clamping , clamping key, TORX® screwdriver, head screws (brass)
	UFA.100.006	Chuck 6 UFA 100 inside	
	UFA.150.006	Chuck 8 UFA 150 inside	
	UFA.070.007	Chuck 6 UFA 70 outside	Chuck with 1-set basic jaws and top jaws for outside clamping , clamping key, TORX® screwdriver, head screws (brass)
	UFA.100.007	Chuck 6 UFA 100 outside	
	UFA.150.007	Chuck 8 UFA 150 outside	
	UFA.070.008	Chuck 6 UFA 70 bloc	Chuck with 1-set basic- and bloc jaws , clamping key, TORX® screwdriver, cylinder head screws (brass)
	UFA.100.008	Chuck 6 UFA 100 bloc	
	UFA.150.008	Chuck 8 UFA 150 bloc	
 	UFA.070.009	Chuck 6 UFA 70 combi	Chuck with 1-set basic jaws and 2-set top jaws for inside and outside clamping , clamping key, TORX® screwdriver, head screws (brass)
	UFA.100.009	Chuck 6 UFA 100 combi	
	UFA.150.009	Chuck 8 UFA 150 combi	



	Article	Designation	Information
CLAMPING JAWS FOR UFA LINE			
	UFA.070.021	Clamping Jaws 6 UFA 70 inside	Soft top jaws for inside clamping
	UFA.100.021	Clamping Jaws 6 UFA 100 inside	
	UFA.150.021	Clamping Jaws 8 UFA 150 inside	
	UFA.070.022	Clamping Jaws 6 UFA 70 outside	Soft top jaws for outside clamping
	UFA.100.022	Clamping Jaws 6 UFA 100 outside	
	UFA.150.022	Clamping Jaws 8 UFA 150 outside	
	UFA.070.023	Clamping Jaws 6 UFA 70 bloc	Bloc jaws
	UFA.100.023	Clamping Jaws 6 UFA 100 bloc	
	UFA.150.023	Clamping Jaws 8 UFA 150 bloc	

FORM FIT CLAMPING WITHOUT MAGNETIC FIELD

Technical data and order overview Type UFA (6 or 8-jaw chuck)

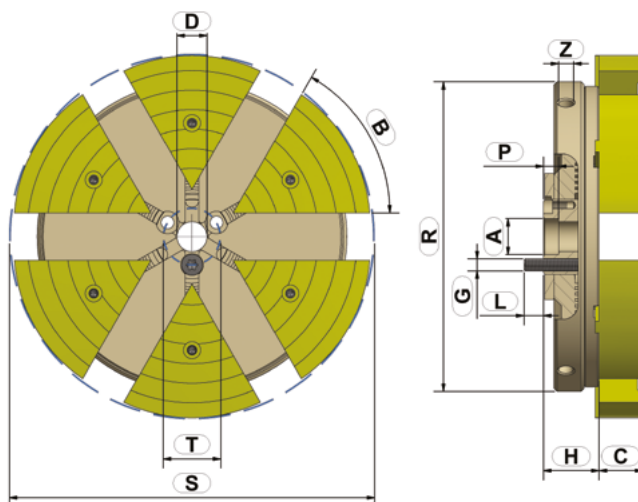

Sizes		70	100	150
A 0/+0,01	Interface [mm]	11	12	20
B	Clamping jaw angle (degree)	60	60	45
C	Jaw height (Standard) [mm]	10,5	14,5	18,5
D	∅ center hole [mm]	8	10	16
G	Fixing screws	3 x M3	3 x M4	4 x M5
H	Height without Jaws [mm]	16	18,5	21,5
L	Thread length [mm]	4,5	6,5	5
P	Fit length [mm]	5	5	5
R	Outside-∅ [mm]	73	103	153
S	Max. circuit diameter [mm]	87,5	119,5	183,5
T	Circle for mounting [mm]	17	18,8	28
Z	Clamping bore [mm]	3	5	5
	Concentricity [mm]	0,3	0,3	0,3
	Rotation speed n max. [1/min.]	2500	2000	1500
	Travel path [mm / ∅]	23,5	36,5	47
	Weight [kg]	0,3	0,7	1,7
	Order number (without jaws)	UFA.070.000	UFA.100.000	UFA.150.000

JAW-SET 6 UFA INSIDE (INSIDE CLAMPING)

Technical data and order overview

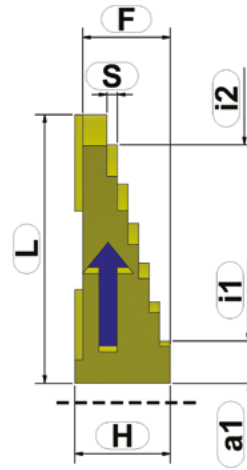

	Sizes	55	70	100	150
a1	Clamping range outside	1 - 16	1 - 24	1 - 37	1 - 48
i1	Clamping range inside min.	10 - 25	12,5 - 36	15 - 51	20 - 67
i2	Clamping range inside max.	47 - 62	52,5 - 76	80 - 116	105 - 152
F	Height from Chuck body	11	12	14,5	18,5
H	Maximum height [mm]	12	13	16	20
L	Total length [mm]	27	29,75	44,5	60
S	Step height	1,25	1,5	1,75	2
	Clamping jaw angle (degree)	60	60	60	45
	Order number (without chuck)	UFA.055.021	UFA.070.021	UFA.100.021	UFA.150.021

JAW-SET 6 UFA OUTSIDE (OUTSIDE CLAMPING)

Technical data and order overview

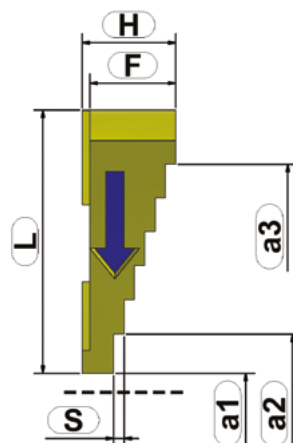

Sizes		55	70	100	150
a1	Clamping range outside	1 - 16	1 - 24	1 - 37	1 - 48
i1	Clamping range inside min.	10 - 25	13,5 - 37	15 - 51	20 - 67
i2	Clamping range inside max.	47 - 62	53,5 - 77	80 - 116	105 - 152
F	Height from Chuck body	11	12	14,5	18,5
H	Maximum height [mm]	12	13	16	20
L	Total length [mm]	27	29,75	44,5	60
S	Step height	1,25	1,5	1,75	2
	Clamping jaw angle (degree)	60	60	60	45
	Order number (without chuck)	UFA.055.022	UFA.070.022	UFA.100.022	UFA.150.022

JAW-SET 6 UFA BLOC (BLOCKBACK)

Technical data and order overview

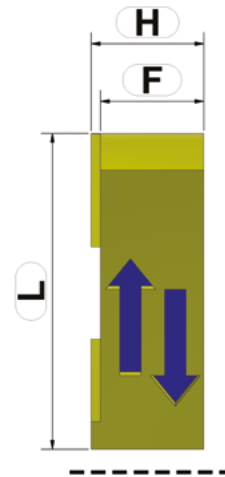

Sizes	70	100	150	
F	Height from Chuck body	12	14,5	18,5
H	Maximum height [mm]	13	16	20
L	Total length [mm]	29,75	44,5	60
	Clamping jaw angle (degree)	60	60	45
	Order number (without chuck)	UFA.070.023	UFA.100.023	UFA.150.023



Swiss Made

